

COLLECT_{AND}DRAIN[®]

Model 5100ALBV

QUALITY COMPONENTS FOR FIRE SPRINKLER SYSTEMS



Auxiliary Drain Water Detectors for Dry and Pre-Action Systems

The AGF COLLECT_{AND}DRAIN Model 5100ALBV water detector is designed to notify personnel that the auxiliary drain or small volume trapped pipe section needs maintenance. Regularly draining the water collected in an auxiliary drain or small volume trapped pipe section in colder temperatures helps prevent freezing and breaking.

The Model 5100ALBV is powered by a 9V battery, 12-24V DC, or an optional 110V plug. When water is detected the Model 5100ALBV sounds an audible alarm and flashes a visual alert. The Model 5100ALBV can be wired to a BMS or fire control panel for remote notification.

Features

- Quarter-Turn Ball Valve
- Audible and Visual Alerts
- BMS or Fire Control Panel Integration
- Optional 110V Plug
- Locking Plate Available

Models

Part Number
5100ALBV



Dimensions

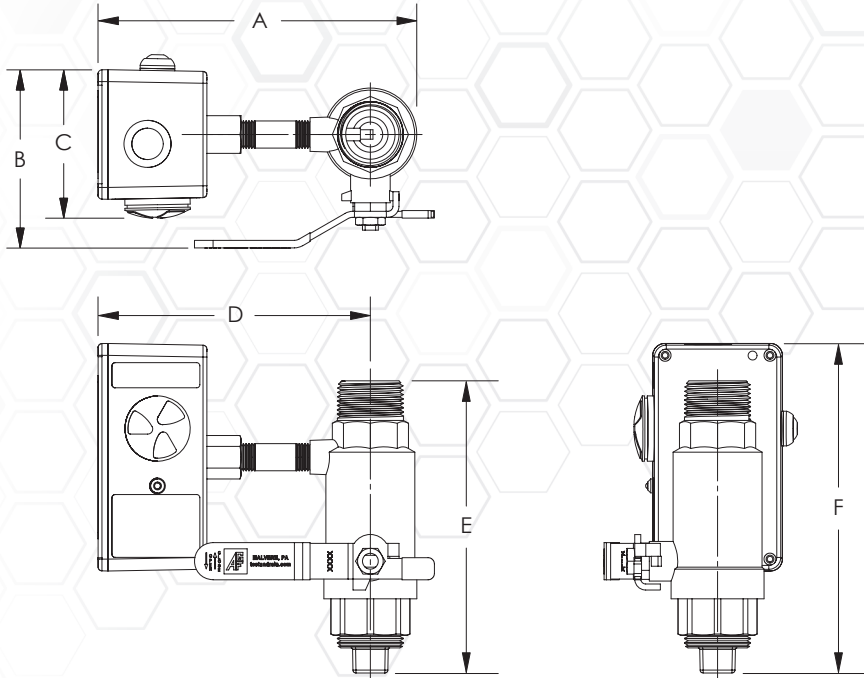

Model	A	B	C	D	E	F
5100ALBV	7" (177 mm)	3 7/8" (98 mm)	3 1/4" (82 mm)	5 1/2" (141 mm)	4 5/8" (117 mm)	5 3/8" (138 mm)

Sizes have been rounded to the highest millimeter

Accessories

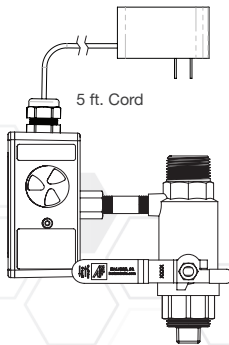

#5100AL-110V Plug Option

Does Not Include 5100ALBV

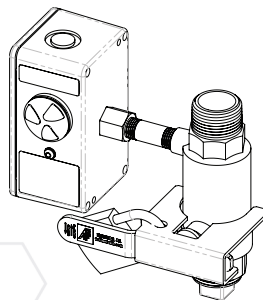

#873 Locking Plate

Does Not Include Lock

USA Patent and Other Patents Pending

For use on dry and pre-action fire sprinkler systems.

Valve Size

1"

Connections

Inlet..... MNPT

Outlet..... FNPT

Installation Orientation

Vertical

Electrical Requirements

9V, 12-24V DC, or 110V AC

Materials

Valve Body..... Brass

Detector Body Aluminum

Ball..... Chrome-Plated Brass

Handle Steel

Drain Plug..... Steel

Rating

300 PSI

Compliance

NFPA 13

NYC-BSA No. 720-87-SM

Approvals

UL/ULC (EX27218)

FM



AGF Manufacturing Inc.
100 Quaker Lane, Malvern, PA 19355

Phone: 610-240-4900
Fax: 610-240-4906

www.agfmfg.com

Job Name: _____

Architect: _____

Engineer: _____

Contractor: _____