

TESTANDRAIN® VALVE REPAIR KIT

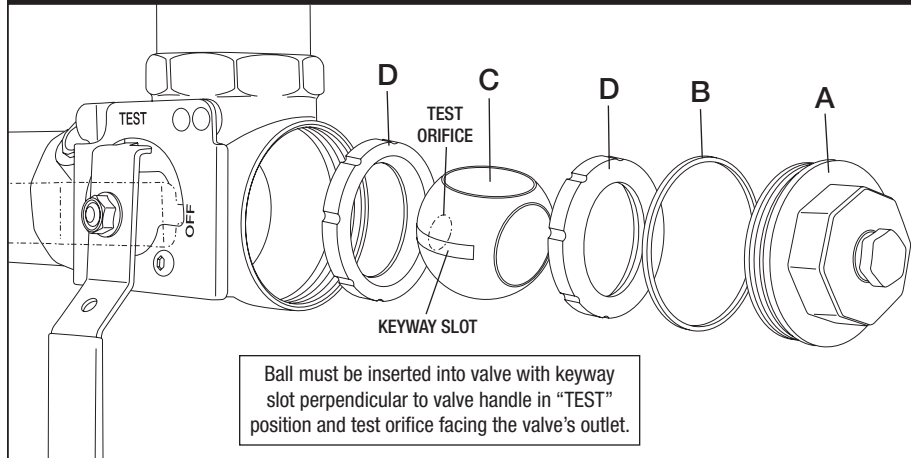

Repair Kit Includes: (1) adapter gasket (B), (1) ball (C), (2) valve seats (D), (1) stem packing (not shown, see Note 1) and (1) stem washer (not shown, see Note 1).

READ ALL INSTRUCTIONS COMPLETELY AND FAMILIARIZE YOURSELF WITH THE PROCEDURE PRIOR TO PERFORMING ANY REPAIR.

Repair Instructions

The following repair instructions are intended to be followed in whole for the repair of 1¼" – 2" valve models. For the repair of ¾" – 1" valve models see additional Note 2 below.

1. Close the sectional control/isolation valve to the section of piping connected to the TESTANDRAIN® valve that is to be repaired.
2. After the piping is isolated, open the TESTANDRAIN® valve to the "DRAIN" position and allow the isolated section of piping to drain completely.
3. Remove the adapter (A) of the TESTANDRAIN® valve by turning the adapter counterclockwise.
4. Remove the first valve seat (D), known as the upstream valve seat, and discard.
5. For 1¼" – 2" valve models, remove the adapter gasket (B) and discard. For ¾" – 1" valve models see Note 2a.
6. Turn the TESTANDRAIN® handle to the "TEST" position. Remove the ball (C).
7. Remove the second valve seat (D), known as the downstream valve seat, and discard. The use of a small tack puller may be required to pull out the downstream valve seat. Take care not to mar the surface of the valve seat shoulder.
8. Flush all debris from the inside of valve body with clear water and wipe clean.
9. Insert (1) new valve seat (D), flat side first, so the flat side of the valve seat rests flush with the flat surface of the valve seat shoulder. To avoid damage to the valve seats, **DO NOT USE ANY TOOLS TO INSTALL THE VALVE SEATS.**
10. The new ball (C) is sent lubricated, **DO NOT REMOVE BALL LUBRICATION.** To insert the new ball (C) orient the ball as follows while maintaining the valve handle in the "TEST" position:

TESTANDRAIN® VALVE REPAIR KIT

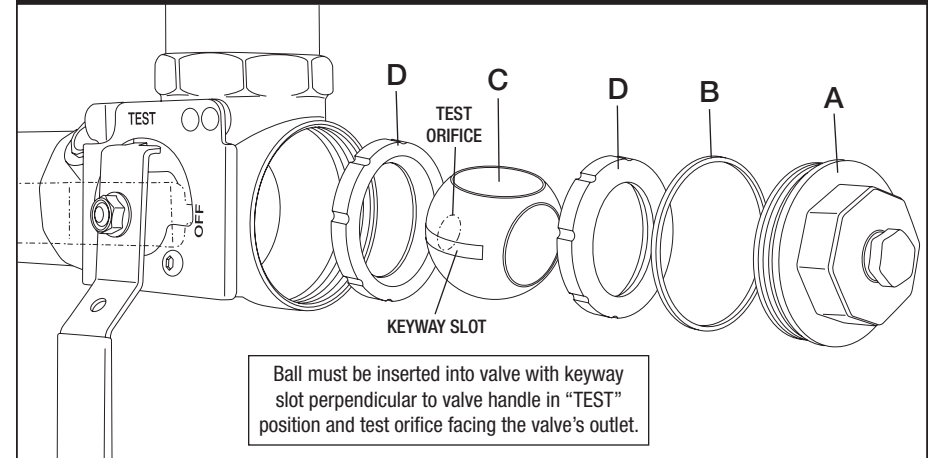

Repair Kit Includes: (1) adapter gasket (B), (1) ball (C), (2) valve seats (D), (1) stem packing (not shown, see Note 1) and (1) stem washer (not shown, see Note 1).

READ ALL INSTRUCTIONS COMPLETELY AND FAMILIARIZE YOURSELF WITH THE PROCEDURE PRIOR TO PERFORMING ANY REPAIR.

Repair Instructions

The following repair instructions are intended to be followed in whole for the repair of 1¼" – 2" valve models. For the repair of ¾" – 1" valve models see additional Note 2 below.

1. Close the sectional control/isolation valve to the section of piping connected to the TESTANDRAIN® valve that is to be repaired.
2. After the piping is isolated, open the TESTANDRAIN® valve to the "DRAIN" position and allow the isolated section of piping to drain completely.
3. Remove the adapter (A) of the TESTANDRAIN® valve by turning the adapter counterclockwise.
4. Remove the first valve seat (D), known as the upstream valve seat, and discard.
5. For 1¼" – 2" valve models, remove the adapter gasket (B) and discard. For ¾" – 1" valve models see Note 2a.
6. Turn the TESTANDRAIN® handle to the "TEST" position. Remove the ball (C).
7. Remove the second valve seat (D), known as the downstream valve seat, and discard. The use of a small tack puller may be required to pull out the downstream valve seat. Take care not to mar the surface of the valve seat shoulder.
8. Flush all debris from the inside of valve body with clear water and wipe clean.
9. Insert (1) new valve seat (D), flat side first, so the flat side of the valve seat rests flush with the flat surface of the valve seat shoulder. To avoid damage to the valve seats, **DO NOT USE ANY TOOLS TO INSTALL THE VALVE SEATS.**
10. The new ball (C) is sent lubricated, **DO NOT REMOVE BALL LUBRICATION.** To insert the new ball (C) orient the ball as follows while maintaining the valve handle in the "TEST" position:

- a. Position the keyway slot on the ball perpendicular to the valve handle.
 - b. The test orifice, the smallest of the three holes in the ball, is to be inserted first. When inserted correctly the test orifice will be located in the "DRAIN" position open to the outlet of the valve.
 - c. Slide the ball keyway slot on to the stem key and push the ball into place against the concave face of the downstream valve seat.
11. Once the ball (C) is inserted correctly, turn the valve handle to the "OFF" position locking the ball in place.
 12. For 1¼" – 2" valve models insert new adapter gasket (B). For ¾" – 1" valve models see Note 2b.
 13. Insert the last new valve seat (D) with the concave face against the ball (C) and thread the adapter (A) back onto the valve body. Refer to the torque chart below for required adapter tightening torque.
 14. Confirm the TEST_{AND}DRAIN[®] valve handle is in the "OFF" position. Open sectional control/isolation valve to refill piping section.

NOTE 1: The stem packing and stem washer are only necessary if the TEST_{AND}DRAIN[®] is passing water through the stem. Should this occur, please call AGF for assistance at 610-240-4900 for TEST_{AND}DRAIN[®] stem repair instructions.

NOTE 2: ¾" – 1" valve model adapter gasket (B) replacement instructions.

- a. The adapter gasket (B) will be found on the adapter (A). Inspect the adapter gasket for damage. **IF** the adapter gasket (B) is found without damage, do not remove. The new adapter gasket (B) should be retained for future repairs.
- b. **IF** the adapter gasket (B) is found damaged, remove. Slip the new adapter gasket (B) onto the adapter (A) and down over the threads of the adapter (A). Take care not to twist or cut the adapter gasket (B). Continue with repair instructions step 13 while taking care that the adapter gasket (B) seats firmly into the valve body while threading the adapter (A) onto the valve body and that it does not become pinched.

REQUIRE ADAPTER TIGHTEN TORQUE	
VALVE SIZE	IN.LBS
¾" – 1"	1,100/1,400
1¼"	1,300/1,600
1½" – 2"	1,500/2,150

Questions?

Call AGF at 610-240-4900 and we'll be happy to assist you.



AGF Manufacturing Inc.
 100 Quaker Lane, Malvern, PA 19355
 Phone: 610-240-4900
 Fax: 610-240-4906
 www.testandrain.com

- a. Position the keyway slot on the ball perpendicular to the valve handle.
 - b. The test orifice, the smallest of the three holes in the ball, is to be inserted first. When inserted correctly the test orifice will be located in the "DRAIN" position open to the outlet of the valve.
 - c. Slide the ball keyway slot on to the stem key and push the ball into place against the concave face of the downstream valve seat.
11. Once the ball (C) is inserted correctly, turn the valve handle to the "OFF" position locking the ball in place.
 12. For 1¼" – 2" valve models insert new adapter gasket (B). For ¾" – 1" valve models see Note 2b.
 13. Insert the last new valve seat (D) with the concave face against the ball (C) and thread the adapter (A) back onto the valve body. Refer to the torque chart below for required adapter tightening torque.
 14. Confirm the TEST_{AND}DRAIN[®] valve handle is in the "OFF" position. Open sectional control/isolation valve to refill piping section.

NOTE 1: The stem packing and stem washer are only necessary if the TEST_{AND}DRAIN[®] is passing water through the stem. Should this occur, please call AGF for assistance at 610-240-4900 for TEST_{AND}DRAIN[®] stem repair instructions.

NOTE 2: ¾" – 1" valve model adapter gasket (B) replacement instructions.

- a. The adapter gasket (B) will be found on the adapter (A). Inspect the adapter gasket for damage. **IF** the adapter gasket (B) is found without damage, do not remove. The new adapter gasket (B) should be retained for future repairs.
- b. **IF** the adapter gasket (B) is found damaged, remove. Slip the new adapter gasket (B) onto the adapter (A) and down over the threads of the adapter (A). Take care not to twist or cut the adapter gasket (B). Continue with repair instructions step 13 while taking care that the adapter gasket (B) seats firmly into the valve body while threading the adapter (A) onto the valve body and that it does not become pinched.

REQUIRE ADAPTER TIGHTEN TORQUE	
VALVE SIZE	IN.LBS
¾" – 1"	1,100/1,400
1¼"	1,300/1,600
1½" – 2"	1,500/2,150

Questions?

Call AGF at 610-240-4900 and we'll be happy to assist you.



AGF Manufacturing Inc.
 100 Quaker Lane, Malvern, PA 19355
 Phone: 610-240-4900
 Fax: 610-240-4906
 www.testandrain.com